

Will the picture be better than cable?

All cable companies compress their HD signals. The result is a degraded signal that is usually inferior to ATSC broadcast. Many factors determine whether your picture quality will be better in every instance. However, your picture quality should greatly improve using your 1byone® ATSC compatible digital antenna.

Can I connect the antenna to multiple televisions?

Yes. However, the signal should only be split between multiple HDTVs if using an amplified antenna.

Troubleshooting

What if I can't receive a signal with my 1byone® antenna?

1. Check to make sure you have correctly connected the antenna to your HDTV or third-party HD receiver. See the Setup Guide under, "Connect the Antenna and Amplifier" in this manual.
2. Re-Scan for Channels. See the Setup Guide under, "Scan for Channels" in this manual.
3. Reposition the antenna in a different location. Maybe higher on a wall or close to a window? Facing the direction of the broadcast tower is usually best. Signal strength will vary based on certain conditions. Distance from the tower, hills, buildings and even tall trees can impact reception. Always re-scan for channels after moving the antenna.
4. This is an amplified antenna. If a signal cannot be received with the external amplifier, remove the amplifier and try again. In some instances, the amplifier may cause self-oscillation, which may interfere with the signal.

One channel is missing.

1. Something may be obstructing the signal. Move the antenna, then re-scan for channels.
2. Try turning the antenna 10 or 20 degrees in either direction to avoid reflection, then re-scan for channels.

The picture or sound freezes while I am watching a channel, or there are boxes in the picture.

This is often caused by a weak or intermittent signal. Try moving the antenna to a different location or aiming it in the direction of the broadcast tower for that channel.

For Optimal Performance

Place your 1byone® antenna in the location with the strongest reception. Typically this will be on a window and facing the broadcaster's tower. A television signal can become weak or intermittent by trying to pass through walls that are exceptionally thick or contain large amounts of metal. Your 1byone® antenna can usually pick up the stronger signals from almost any direction. Experiment with different walls and even different rooms to find the best location to mount your antenna. To check the exact distance from your residence to the nearest tower, go to - <http://dtv.gov/maps> and type in your zip code. You will then have a better idea of what you should expect in the way of reception. If there are multiple tower locations, optimize the position of your 1byone antenna by pointing it in the direction of the weakest signal (usually the farthest away from you).

Customer Service/Kundenservice/Service Clients Atención al cliente/Assistenza Clienti/カスタマーサービス

US

To ensure speedy handling of your issue, please call or email us for assistance.
Phone: +1 909-391-3888
(Mon-Fri 9:00am - 6:00pm PST)
Email: ushelp@1byone.com

UK

To ensure speedy handling of your issue, please call or email us for assistance.
Phone: +44 158 241 2681
(Mon-Fri 9:00am - 6:00pm UTC)
Email: ukwebhelp@1byone.com

FR

Pour vous assurez une assistance rapide en cas de problème, veuillez envoyer un e-mail.
Email: euhelp@1byone.com

IT

Per supporto immediato in caso di bisogno, la invitiamo a contattarci via email.
Email: euhelp@1byone.com

CA

To ensure speedy handling of your issue, please email us for assistance.
Email: cahelp@1byone.com

DE

Für eine zügige Bearbeitung ihres Problems, melden Sie sich bei uns wie folgt.
Email: euhelp@1byone.com

ES

Para garantizar una rápida atención de su problema, favor envíenos un email para ayudarlo.
Email: euhelp@1byone.com

JP

お客様の問題が直ちに解決されるため、ぜひメールにて弊社までご連絡ください。
Eメール: jphelp@1byone.com



Amplified Digital Outdoor HDTV Antenna

Model 200NA-0012



Congratulations! You have just purchased the finest, technologically advanced, easy-to-install HD digital antenna for indoor/outdoor use. **1byone®** products have been rated "best sellers." We hope your investment in this quality antenna will give you and your family years of enjoyment. Thank you for your purchase and your support. We invite you to visit our website at www.1byone.com for other high-quality products.

Package Contents -

- Antenna
- 26ft 3C2V cable
- External Amplifier
- 5ft USB Power Cable
- Optional USB Adapter 5V 200mA
- 3M Adhesive Mounting Stickers
- 2 Sets Screws and Plastic Plugs
- Instruction Manual
- Warranty Card

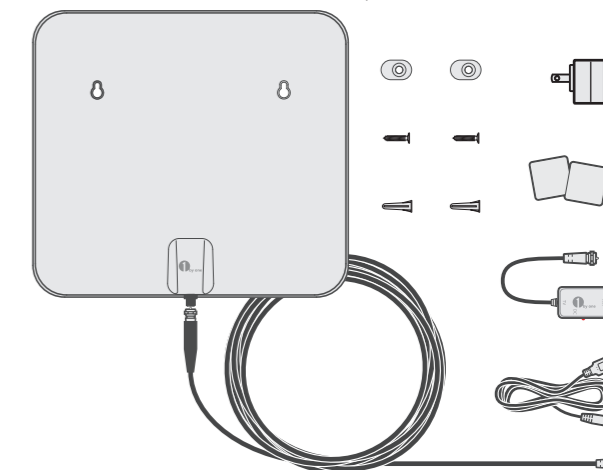

www.1byone.com

Distributed by
1byone Products Inc.
1230 E Belmont Street, Ontario, CA 91761
Customer Service: +1 909-391-3888
www.1byone.com

50 mile maximum range possible. Individual experiences may vary.

A. Connect the F male connector of the 3C2V coaxial cable to the F female connector on the antenna and the other size F male connector of 3C2V cable to the external amplifier (as shown in figure 1 below). **Note:** It is not necessary to attach the external amplifier in areas that have a strong signal. It is best to attach the amplifier in areas with weak signals.

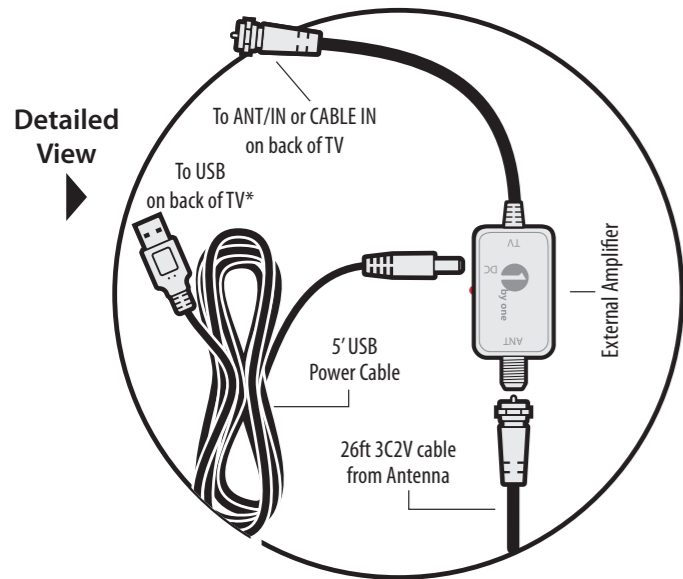
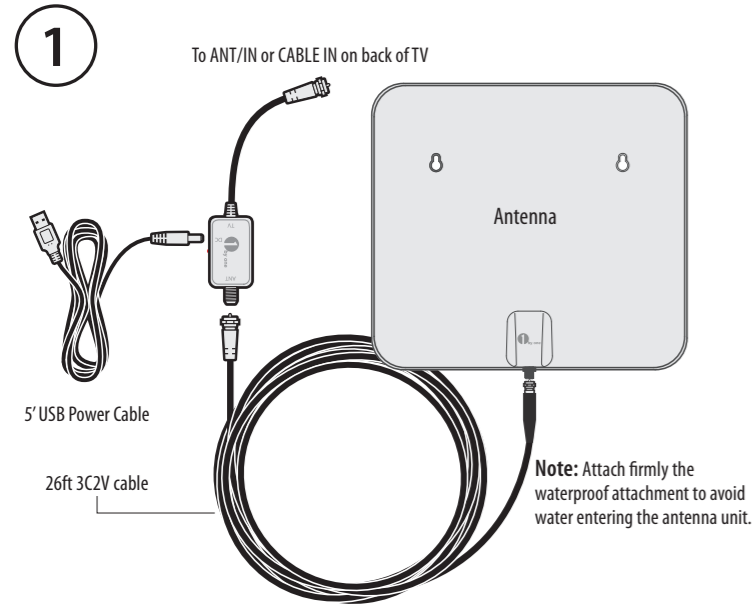

1. Connect the Antenna and Amplifier

B. Connect the coaxial cable from the amplifier to the **ANT/IN** or **CABLE IN** port on the back of your TV (as shown in figure 2). Note: For TV's that require a tuner box, connect the coaxial cable from the amplifier to the tuner box ANT/IN or CABLE IN port. See the "Final Configuration" Illustrations below for both connection options-

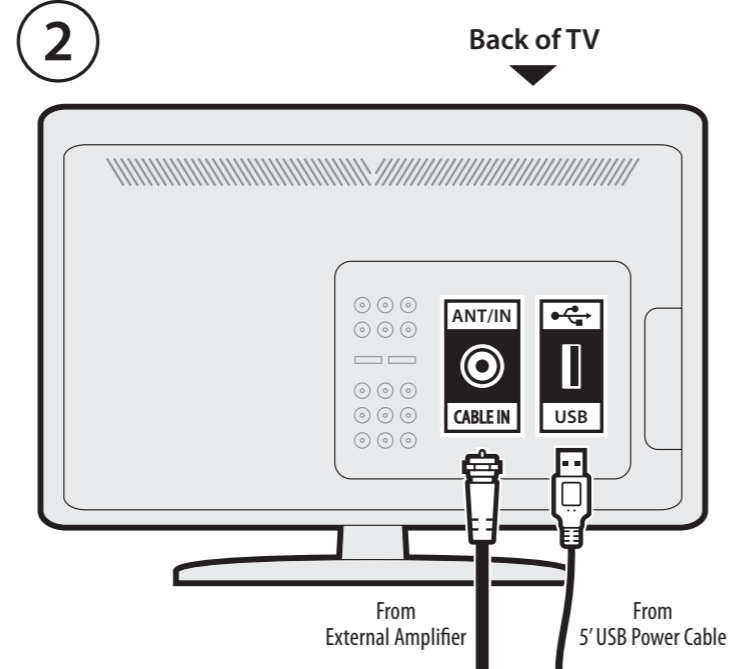

Final configuration when connected to HDTV with built in digital tuner

USB Power Cable shown using optional 100-240V power adapter*

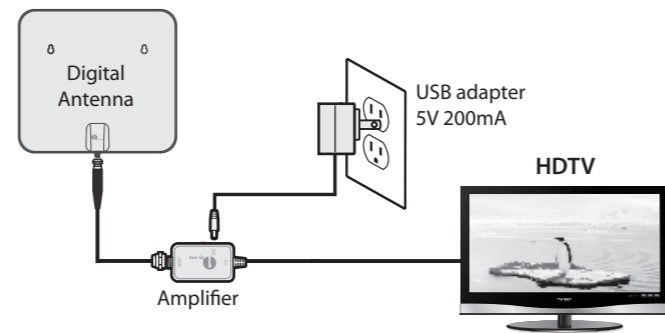

*USB Power Cable may also be plugged into any available USB port on HDTV as well.

C. The amplifier requires power to operate properly. Plug the round end of the amplifier's 5ft long USB power cable into the amplifier (as shown in figure 1). Then insert the USB plug into an open USB port on the back of your TV (see figure 2). If no USB port is available, use the supplied power adapter to power the amplifier through any standard 110V outlet (see this option in figure 3).

3

Power Option For USB Power Cable

For use when no USB port is available on the TV.

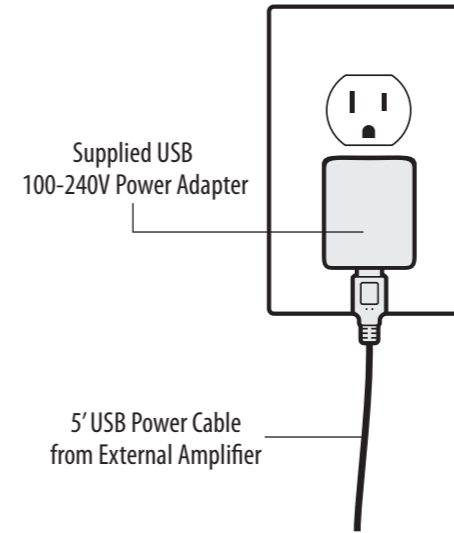
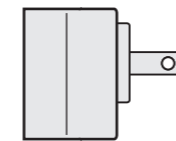

Final configuration when connected to TV through digital tuner converter box

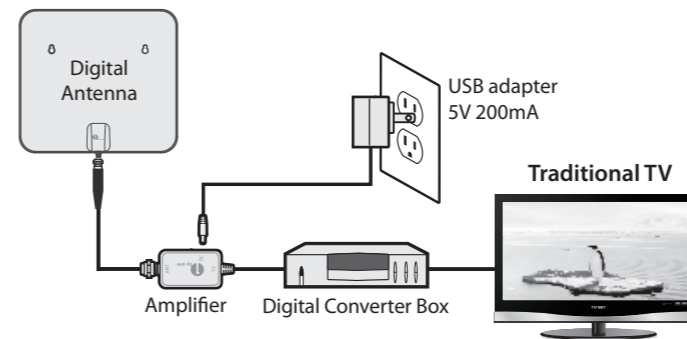

2. Mount Antenna

This antenna has Anti UV coating and weather resistant nish, it is highly recommended to mount it outdoor for better reception.

Find a convenient indoor location to mount your antenna then, set up the channels in the following, "Scan For Channels" step below.

Note: Test your antenna location after scanning for channels & before final mounting. In some instances, you may decide to relocate the antenna for better reception. See "Antenna Placement Options and Tips" below.

3. Scan for Channels

A. In the TV's setup menu, set the mode to Antenna or Air. Refer to the TV manual for detailed instructions.

B. While in the TV's setup menu, set TV to scan for channels. This can sometimes be listed as auto-program, channel search or channel scan. Consult your TV manual for detailed instructions.

Antenna Placement Options and Tips

TV reception and quality depends on the distance from the transmitting tower to your home. Surrounding environments may also affect signal strength and reception.

If your reception is sporadic or needs to be improved, try the helpful tips below,

1. Placing the antenna in a higher location may result in better reception.
2. Placing the antenna facing the broadcast tower may result in better reception.
3. If the TV antenna is placed indoor, suggest place it close to or on a window may also result in better reception.

Important: Always re-scan for channels whenever you move your antenna.

Frequently Asked Questions

How many channels can I receive?

The number of channels you can receive will be determined by what is being broadcast in your area. Channel reception will vary from location to location based on terrain (including trees, buildings, hills and mountains). The fewer obstructions, the better your chance of receiving strong digital signals. Go to <http://dtv.gov/maps>. Enter your address for a listing of likely channels available in your area.

Do I need to use the External Amplifier?

The amplifier can enhance signals weakened by obstructions between you and the broadcast towers. If your TV picture is not crystal clear, or you are unable get weak signals from distant towers, you need to use this amplifier to boost the weakened signals.

Note: We do NOT recommend using the amplifier if your house is very close to the broadcast tower and the signal is already very strong. A booster will cause self-oscillation and you may actually end up getting fewer signals than without it.

Will all the channels I receive be High Definition (HD)?

Not all digital signals are High Definition (HD). Make sure you are using a High Definition Television (HDTV) with built in ATSC tuner. When connecting the antenna to a third-party receiver, make sure it is capable of receiving HD. Otherwise no HD channels can be picked up.