

### Will all the channels I receive be High Definition (HD)?

Not all digital signals are High Definition (HD). Make sure you are using a High Definition Television (HDTV) with built in ATSC tuner. When connecting the antenna to a third-party receiver (set-top box), make sure it is capable of receiving HD. Otherwise no HD channels can be viewed.

### Will picture quality be better than with cable?

All cable companies compress their HD signals. The result is a degraded signal that is usually inferior to ATSC broadcast. Many factors determine whether your picture quality will be better in every instance. However, your picture quality should improve using your 1byone® ATSC compatible digital antenna.

### Can I connect the antenna to multiple televisions?

Yes. However, the signal should only be split between multiple HDTVs if using an amplified antenna.

## Troubleshooting

### What if I can't receive a signal with my 1byone® antenna?

1. Check to make sure you have correctly connected the antenna to your HDTV or third-party HD receiver. See "Connect the Antenna to TV or Set-top Box" in this manual.
2. Re-scan for channels. See "Scan for Channels" in this manual.
3. Reposition the antenna in a different location, such as higher on a wall or closer to a window. Also try facing the antenna directly towards the broadcast tower. Signal strength will vary based on the surrounding conditions. Distance from the tower, and surrounding hills, buildings and even tall trees can impact reception. Always re-scan for channels after moving the antenna.

### One channel is missing.

1. Something may be obstructing the signal. Move the antenna and re-scan re-scan for channels.
2. Turn the antenna 10-20 degrees in either direction and re-scan for channels.

### The picture or sound freezes while I am watching a channel, or there are boxes in the picture.

This is often caused by a weak or intermittent signal. Try moving the antenna to a different location or aiming it in the direction of the tower the channel is being broadcast from.

## For Optimal Performance

Place your 1byone® antenna in the location with the strongest reception. Typically this will be on a window and facing the broadcast tower. A television signal can become weak or intermittent when passing through walls that are exceptionally thick or contain large amounts of metal. Your 1byone® antenna can usually pick up the stronger signals from almost any direction. Experiment with different walls and even different rooms to find the best location to mount your antenna. To check the exact distance from your residence to the nearest tower, go to <http://dtv.gov/maps> and type in your zip code. You will then have a better idea of what you should expect in the way of reception. If there are multiple tower locations, optimize the position of your 1byone antenna by pointing it in the direction of the weakest signal (usually the farthest away from you).

## Customer Service/Kundenservice/Service Clients Atención al cliente/Assistenza Clienti/カスタマーサービス

### US

To ensure speedy handling of your issue, please call or email us for assistance.

Phone: +1 909-391-3888

(Mon-Fri 9:00am - 6:00pm PST)

Email: [ushelp@1byone.com](mailto:ushelp@1byone.com)

### UK

To ensure speedy handling of your issue, please call or email us for assistance.

Phone: +44 158 241 2681

(Mon-Fri 9:00am - 6:00pm UTC)

Email: [ukwebhelp@1byone.com](mailto:ukwebhelp@1byone.com)

### FR

Pour vous assurez une assistance rapide en cas de problème, veuillez envoyer un e-mail.

Email: [euhelp@1byone.com](mailto:euhelp@1byone.com)

### IT

Per supporto immediato in caso di bisogno, la invitiamo a contattarci via email.

Email: [euhelp@1byone.com](mailto:euhelp@1byone.com)

### CA

To ensure speedy handling of your issue, please email us for assistance.

Email: [cahelp@1byone.com](mailto:cahelp@1byone.com)

### DE

Für eine zügige Bearbeitung ihres Problems, melden Sie sich bei uns wie folgt.

Email: [euhelp@1byone.com](mailto:euhelp@1byone.com)

### ES

Para garantizar una rápida atención de su problema, favor envíenos un email para ayudarlo.

Email: [euhelp@1byone.com](mailto:euhelp@1byone.com)

### JP

お客様の問題が直ちに解決されるため、ぜひメールにて弊社までご連絡ください。

Eメール: [jphelp@1byone.com](mailto:jphelp@1byone.com)



## Amplified Digital Indoor/Outdoor HDTV Antenna New Concept Series - 80 Miles Range

Model 210NA-0003



**Congratulations!** You have just purchased the purchased the most technologically advanced, easy-to-install, indoor/outdoor HD digital antenna available. **1byone®** products have been consistently rated as "best sellers" and we hope your investment in this quality antenna will give you and your family enjoyment for years to come. Thank you for your purchase and your support. We invite you to visit our website at [www.1byone.com](http://www.1byone.com) for other high-quality products.

### Package Contents -

Antenna with Built-in Amplifier  
Power Supply Box and Switching Adapter  
Mast Clamp  
20ft Cable with Waterproof Cap  
Plastic Wrench (Spanner)

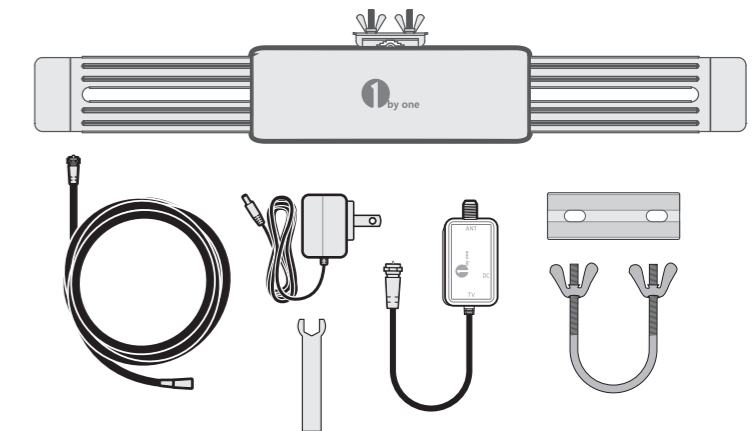

**1byone Products Inc.**  
1230 E Belmont Street, Ontario, CA 91761  
Customer Service: +1 909-391-3888

[www.1byone.com](http://www.1byone.com)

*80 mile maximum range possible. Individual experiences may*

[www.1byone.com](http://www.1byone.com)

## 1. Connect the Antenna and Power Supply Accessories

- A.** Connect the 20ft long coaxial cable to the antenna (as shown in figure 1 below)  
Use the included plastic wrench (spanner) to better tighten the cable's connector.

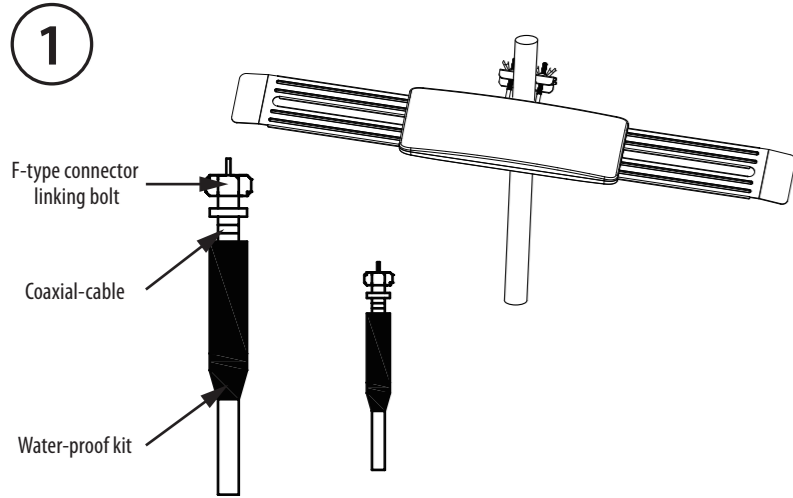

- B.** Connect the other end of the 20ft coaxial cable to the power supply box (as shown in figure 2 below).

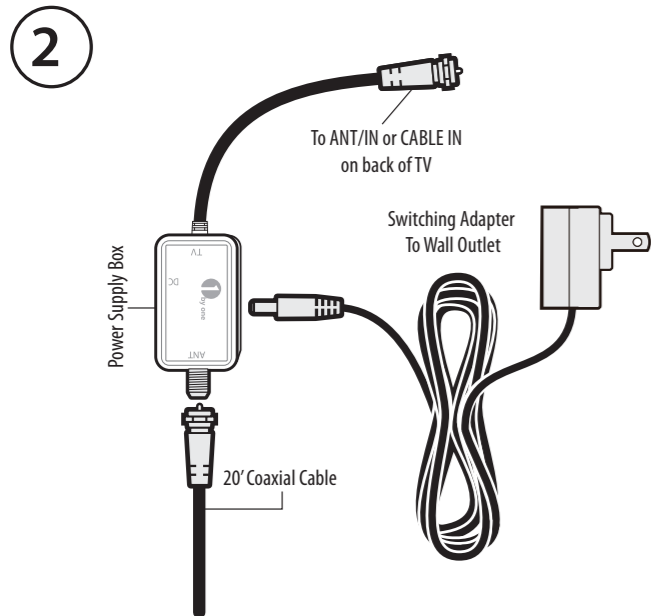

- C.** Connect the coaxial cable from the power supply box to the **ANT/IN** or **CABLE IN** port on the back of your TV (as shown in figure 3). Note: For TV's that require a tuner box, connect the coaxial cable from the power supply box to the tuner box ANT/IN or CABLE IN port.

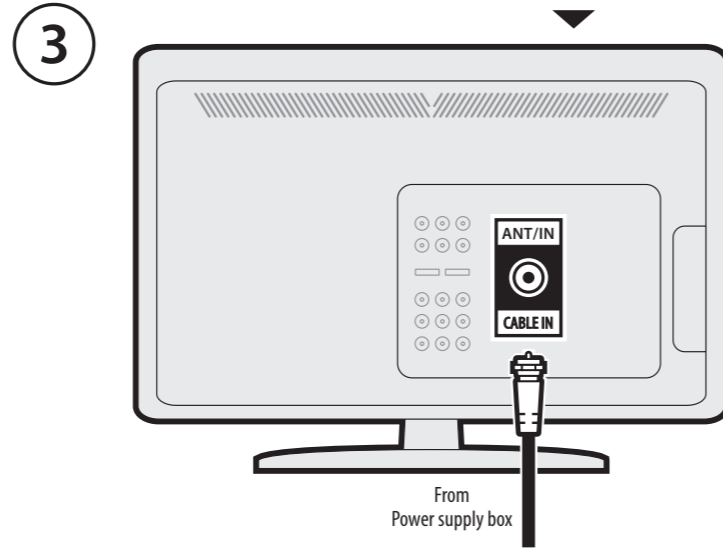

- D.** The antenna's built-in amplifier requires power to operate properly. Plug the round end of the switching adapter's power cable into the power supply box (as shown in figure 2). Then insert the switching adapter into any standard 110V outlet (see this option in figure 4).

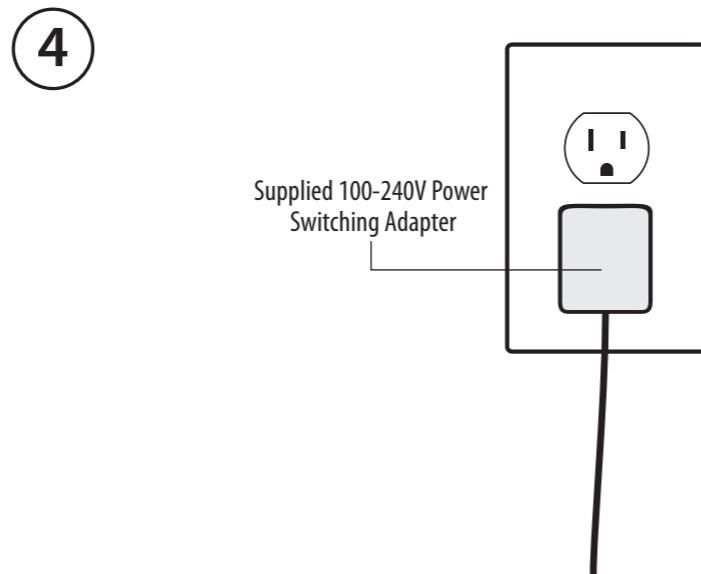

## 2. Mount Antenna

Find a convenient location to mount your antenna.

- (Fig.1) Use the screws and wall mounting accessories to fix the antenna on the wall

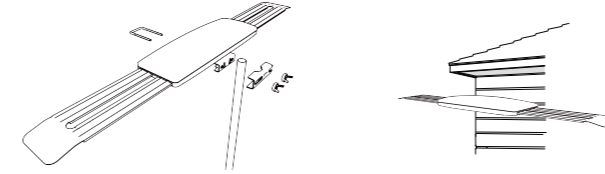

- (Fig.2) Use the mounting accessories to fix the antenna on the balcony.

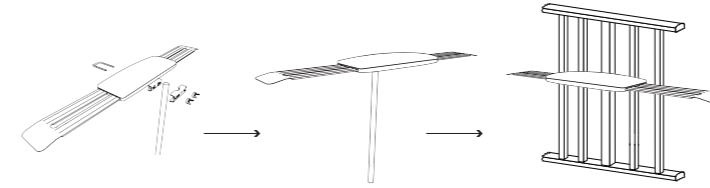

- (Fig.3) Use the pole mounting accessories to fix the antenna on the pole.

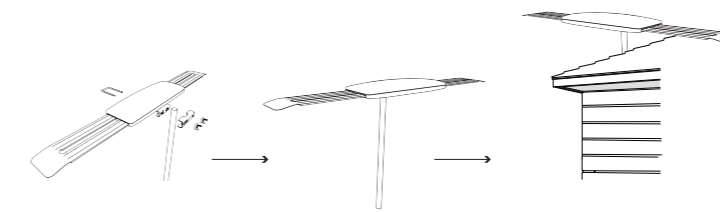

**Note:** Test your antenna location after scanning for channels & before final mounting. In some instances, you may decide to relocate the antenna for better reception. See "Antenna Placement Options and Tips".

## 2. Mount the Antenna

Find a convenient indoor/outdoor location to mount your antenna, then scan for channels using the instructions below.

**Note:** Before final mounting, first test your selected antenna location by scanning for channels. In some instances, you may decide to relocate the antenna for better reception. See below for addition tips for optimal antenna placement.

If you need a mounting pole to install the antenna, you can purchase 1byone mounting pole Model #OUS00-0660(black) for convenient pole placement.

Note: Antenna mounting pole is sold separately at [www.1byone.com](http://www.1byone.com)

## 3. Scan the TV for Channels

- A.** In the TV's setup menu, set the mode to 'Antenna' or 'Air.' Refer to the TV manual for detailed instructions.

- B.** While in the TV's setup menu, set TV to scan for channels. This can sometimes be listed as 'auto-program,' 'channel search,' or 'channel scan.' Refer to your TV manual for detailed instructions.

Note: If you want to know how many channels you can expect to receive, please refer to "How many channels can I receive?" in FAQ below.

## Antenna Placement Options and Tips

Signal reception and quality depends on the distance from the broadcast tower to your home. Surrounding geography and environment may also affect signal strength and reception.

If your reception is sporadic or needs to be improved, try the helpful tips below:

1. Place the antenna in a higher location.
2. Face the antenna towards the nearest broadcast tower.
3. Place the antenna in line of sight with the TV tower(s) and avoid obstructions.

**Important:** Always re-scan for channels whenever you move your antenna.

## Frequently Asked Questions

### How many channels can I receive?

The number of channels you can receive will be determined by what is broadcast in your area. Channel reception will vary from location to location based on terrain (including trees, buildings, hills and mountains). The fewer obstructions, the better your chance of receiving strong digital signals. Go to <http://dtv.gov/maps> and enter your address for a listing of likely channels available in your area.